

SOT23-3L

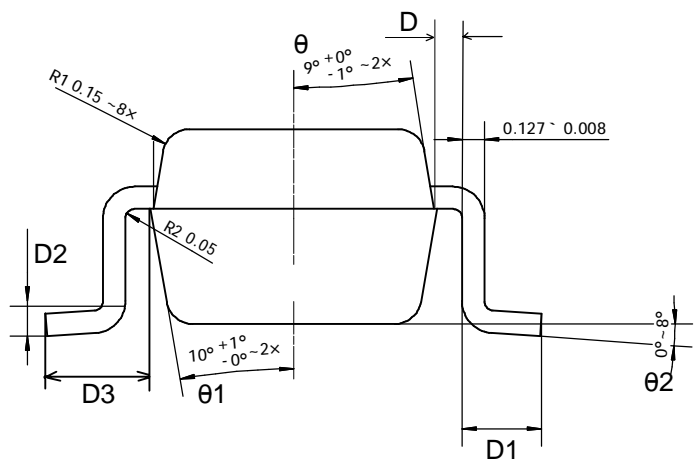

COMMON DIMENSIONS			
UNITS MEASURE=MILLIMETER			
SYMBOL	MIN	NOM	MAX
A	2.82	2.92	3.02
A1	0.90	0.95	1.0
A2	0.35	0.4	0.45
B	1.52	1.62	1.72
B1	2.80	2.90	3.0
B2	0.12	0.128	0.135
C	1.05	1.10	1.15
C1	0.03	0.08	0.13
C2	0.6	0.65	0.7
D	0.03	0.08	0.13
D1	0.4	0.45	0.5
D2	0.25TYP		
D3	0.6	0.65	0.7

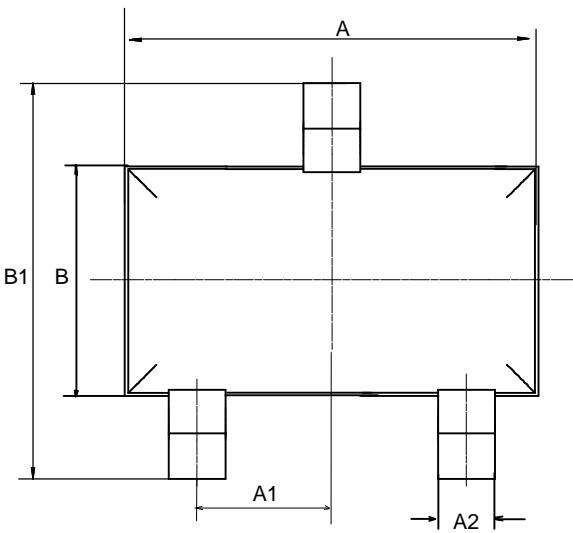
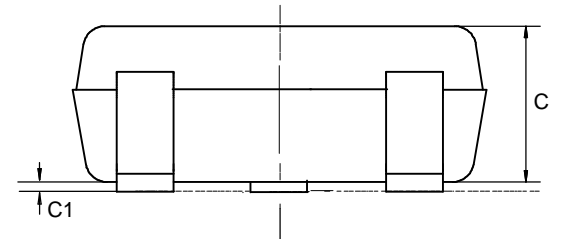
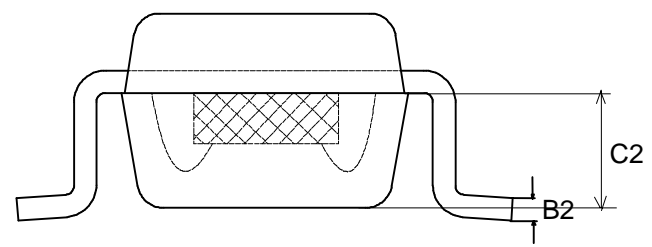

浙江亚芯微电子股份有限公司

					SOT-23-3L		编号	
							09	
标记	数量	分区	更改文件号	签名	年.月.日	阶段标记	重量(Kg)	比例
设计	Administrative	2017-3-15	标准化					
审核								
工艺			批准					